

Mixed I/O Module

for the MOSCAD RTU

The Mixed Input/Output module is an accessory to the MOSCAD RTU family that permits up to eight dry-contact closures, from switches or relays in other on-site equipment, to be connected to the RTU. Up to two 4-20 ma analog inputs, from on-site tank level or flow-rate sensors may be connected to the RTU. It also provides four relay outputs that may control on-site electrical devices.



FEATURES/BENEFITS

Time-Tagging

Any of the eight digital inputs may be defined to tag the time of the input event with one millisecond accuracy.

- ▶ This time may be read and used in sequence-of-event actions or used for historical reports.

.....

Relay Outputs

Different modules are available with four electrically-energized (EE) relays or with three magnetically-latched (ML) plus one electrically-energized relays.

- ▶ The all-EE relay version should be used when it is mandatory that the relays open when power is lost or control is disrupted. The 3ML-1EE relay version should be used when prolonged operation from the backup battery power source is expected.

.....

Optical Isolation

All digital and analog inputs are protected by optical isolators on the module.

- ▶ Surge Withstand Capability (SWC) conformance is assured for the safety of the equipment and technicians.

.....

Packaging

The module is packaged in a plastic housing that plugs, and locks, into the motherboard. Wire connections (up to 14 ga. wire) are made to removable connectors on the face of the module. No jumpers, calibration pots, etc. are located on the module (any calibration is done electronically via software from the ToolBox program.)

- ▶ Modularity allows the MOSCAD RTU to be easily expanded as system requirements change and makes field module replacement quick and easy.

.....

Digital Data Input

Under the control of the defined Application Program, the CPU module in the RTU will read the current instantaneous status of one or more of the eight status inputs or two analog inputs. It moves that data from the module into the CPU module via the motherboard.

- ▶ This data may be used by the Application Program. Similarly, the CPU module will move data associated with the four relays into the module and may control the state of those relays.

.....

Low-Speed Counter Inputs

Each of the eight digital inputs may be used as low-speed counter inputs. The totalizing must be done within the CPU module under Application control. The Application must read the associated input(s) in a timely manner to assure the operator will not miss any input event.

- ▶ Any number of counter inputs are easily obtained.

.....

GENERAL SPECIFICATIONS

| | |
|----------------------------------|--|
| Order: | 4-20 ma w/3ML+EE: plant-V245, field: FRN 1484 4-20 ma w/4EE: plant-V436, field: FRN 1490 ±1 V w/4EE: plant-V453, field: FRN 1997 |
| Digital Inputs: | 8; may be counters (50 Hz or less) |
| DI Source Resistance: | Close: <4 k ohm Open: >70 k ohm |
| Digital Input Isolation: | On-board DC/DC converter; optical isolation |
| Digital Input Protection: | 2.5 kV oscillatory SWC per ANSI C37.90.1-1989 |
| Analog Inputs: | Two; 4-20 ma or ± 1 V |
| Input Resistance: | 4-20 ma: 226 ohm, ± 1V: 11 k ohm |
| Resolution: | 12 bits (including sign) over full ±20 ma range |
| Overall Accuracy: | 0.05% |
| Relay Outputs: | 4 relays, either all Electrically-energized (EE) or 3 Magnetically-latched and 1 EE |
| Contact Rating: | 60W or 125 VA, not to exceed 2 amp and 250 volts |
| Output Protection: | 1 kV between contacts, 1.5 kV between contact & coil per ANSI C37.90.1-1989 |
| Diagnostic: | 20 LEDs: 16 for outputs, 1 each for Module Fail and No Clock |
| Power: | 5 Vdc: 20 ma 12 Vdc: ML: 30 ma (70 ma with LEDs on) EE: 75 ma (115 ma with LEDs on) |
| Environment: | Humidity: 0 to 90% @ +50°C Temperature: -30 to +60°C |

Typical Digital Input Circuit

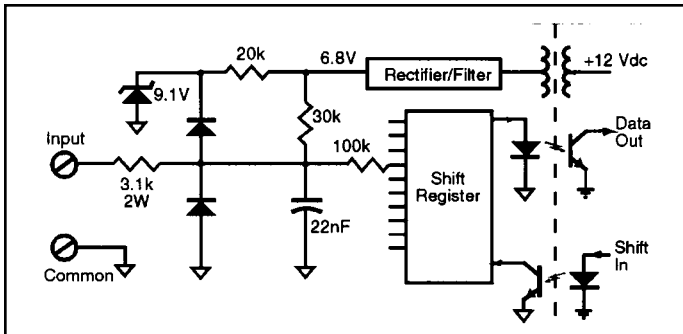

Typical Analog Input Circuit

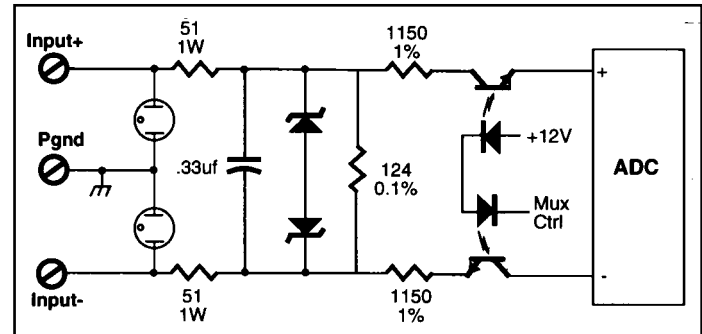

Typical Relay Output Circuit

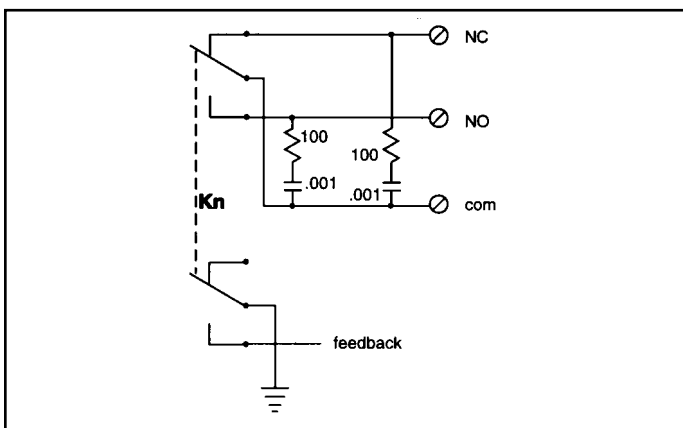

Specifications subject to change without notice.

Connections Chart

| Term | Function | Term | Function |
|------|--------------------|------|------------------|
| 1 | Analog Input 1 (+) | 13 | Digital Input 8 |
| 2 | Analog Input 1 (-) | 14 | DI common |
| 3 | Analog Input 2 (+) | 15 | K1 NC (EE or ML) |
| 4 | Analog Input 2 (-) | 16 | K1 NO |
| 5 | P. Ground | 17 | K1 common |
| 6 | Digital Input 1 | 18 | K2 NC (EE or ML) |
| 7 | Digital Input 2 | 19 | K2 NO |
| 8 | Digital Input 3 | 20 | K2 common |
| 9 | Digital Input 4 | 21 | K3 NC (EE or ML) |
| 10 | Digital Input 5 | 22 | K3 common |
| 11 | Digital Input 6 | 23 | K4 NO (EE only) |
| 12 | Digital Input 7 | 24 | K4 common |



MOTOROLA

Motorola U.S.A.
1301 E. Algonquin Road
Schaumburg, Illinois 60196
In the U.S. call: 1-800-247-2346

Motorola Canada Limited
3900 Victoria Park Avenue
North York, Ontario M2H 3H7
In Canada call: 1-800-268-5758

Outside the U.S. and Canada call: (847) 538-6602

©, and Motorola are trademarks of Motorola, Inc. © 1994
Motorola, Inc. Printed in U.S.A. (9712) Merit Produced by
Customer Communications.

Motorola is an Equal Employment Opportunity/Affirmative
Action Employer



Midgårdsvägen 20, S-973 34 LULEÅ
Tel: 0920-22 24 10, Fax: 0920-22 24 20
E-Mail: info@vianetab.se
Gsm: 070-545 14 52, 070-545 17 81



Support Services

Wherever Motorola sells, our product is backed by service. Our products are serviced throughout the world by a wide network of company or authorized independent distributor service organizations.