

# 16DO Digital Output Module

## for the MOSCAD RTU

### FEATURES/BENEFITS

The 16 Digital Output module is an accessory to the MOSCAD RTU family that provides 16 relay outputs that may be connected to, and used to control other on-site electrical devices. Examples include lighting circuits, control circuits and interpose relays.



#### Magnetically-Latched Relays

The magnetic-latched relay module has 16 latch-type relays. These relays have two coils each plus a small internal magnet. The relay is closed by briefly energizing the Set coil—the magnet then keeps the relay closed. Similarly, the relay is opened by briefly energizing the Reset coil.

► This type of relay module should be used when prolonged operation from the backup battery power source is expected. There is no sustained current drain from the battery to keep the relay(s) closed.

.....

#### Activation Feedback

Both types of 16DO modules have secondary contacts on the relays that provide positive feedback that the relay has closed.

► This feedback may be treated as digital inputs and incorporated into the Application when required.

.....

#### Packaging

The module is packaged in a plastic housing that plugs, and locks, into the motherboard. Wire connections (up to 14 ga. wire) are made to removable connectors on the face of the module. No jumpers, calibration pots, etc. are located on the module (any calibration is done electronically via software from the ToolBox program.)

► Modularity allows the MOSCAD RTU to be easily expanded as system requirements change and makes field module replacement quick and easy.

.....

#### Data Output

Under the control of the defined Application Program, the CPU module in the RTU will move the current status of the data variables in the CPU module that are associated with the relays to the 16DO module via the motherboard. The 16DO module then opens or closes relays according to the status of this data.

► The application in the CPU module determines the state of the output relays using data obtained throughout the system.

.....

#### Electrically-Energized Relays

The electrically-energized relay module has 16 conventional relays. These relays have a single coil each. The relays remain closed for as long as their coils are energized.

► This type of relay module allows user control when it is mandatory that the relays open when power is lost or control is disrupted.

.....

# 16DO Digital Output Module

## SPECIFICATIONS

### GENERAL SPECIFICATIONS

<b>Order:</b>	Plant Installed:	Magnetically-latched-V516; Electrically-energized-V616
	Field Installed:	Magnetically-latched-FRN1492; Electrically-energized-FRN1491
<b>Output:</b>	16 relays, all either Magnetically-Latched (ML) or Electrically-Energized (EE)	
<b>Contact Rating:</b>	60W or 125 VA, not to exceed 2 amp and 250 volts	
<b>Output Protection:</b>	1 kV between contacts, 1.5 kV between contact & coil per ANSI C37.90.1-1989	
<b>Diagnostic:</b>	20 LEDs: 16 for outputs, 1 each for Module Fail and No Clock	
<b>Power:</b>	5 Vdc:	5 ma (ML), 25 ma (EE)
	12 Vdc:	ML: 5 ma (45 ma with LEDs on) EE: 260 ma (300 ma with LEDs on)
<b>Environment:</b>	Humidity:	0 to 90% @ +50°C
	Temperature:	-30 to +60°C

### Typical Output Circuit

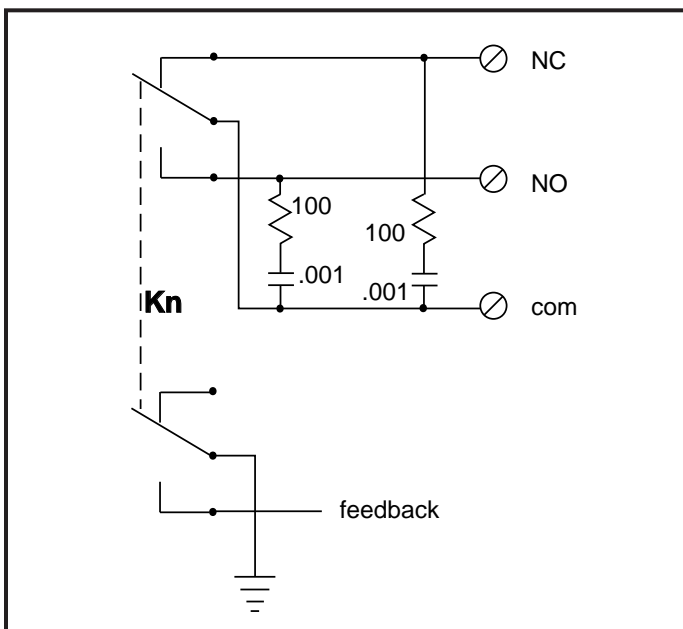

### Connections Chart

Term	Function	Term	Function
1	K1 NO	13	K8 NO
2	K1 NC	14	K5-8 com
3	K2 NO	15	K9 NO
4	K2 NC	16	K10 NO
5	K3 NO	17	K11 NO
6	K3 NC	18	K12 NO
7	K4 NO	19	K9-12 com
8	K4 NC	20	K13 NO
9	K1-4 com	21	K14 NO
10	K5 NO	22	K15 NO
11	K6 NO	23	K16 NO
12	K7 NO	24	K13-16 com

Specifications subject to change without notice.



Midgårdsvägen 20, S-973 34 LULEÅ  
 Tel: 0920-22 24 10, Fax: 0920-22 24 20  
 E-Mail: [info@vianetab.se](mailto:info@vianetab.se)  
 Gsm: 070-545 14 52, 070-545 17 81



### Support Services

Wherever Motorola sells, our product is backed by service. Our products are serviced throughout the world by a wide network of company or authorized independent distributor service organizations.



**MOTOROLA**

Motorola U.S.A.  
 1301 E. Algonquin Road  
 Schaumburg, Illinois 60196  
 In the U.S. call: 1-800-247-2346

Motorola Canada Limited  
 3900 Victoria Park Avenue  
 North York, Ontario M2H 3H7  
 In Canada call: 1-800-268-5758

Outside the U.S. and Canada call: (847) 538-6602

© and Motorola are trademarks of Motorola, Inc. ■ © 1994 Motorola, Inc. ■ Printed in U.S.A. ■ (9808) Merit ■ Produced by Customer Communications.

Motorola is an Equal Employment Opportunity/Affirmative Action Employer