

16ac Digital Input Module

for the MOSCAD RTU

FEATURES/BENEFITS

The 16ac Digital Input module is an accessory to the MOSCAD RTU family that allows up to 16 AC or DC voltages, from other on-site equipment, to be connected to the RTU. Examples include site or equipment door switches, centrifugal switches on motors, equipment malfunction switches and tank float switches.



Data Input

Under the control of the defined Application Program, the CPU module in the RTU will read the current instantaneous status of one or more of the 16 inputs, and move that data from the 16ac Digital Input module into the CPU module via the motherboard.

► This data may then be used by the Application Program to perform the desired functions.

Low-Speed Counter Inputs

Each of the 16 digital inputs may be used as low-speed counter inputs. The totalizing will be done within the CPU module under Application control.

► Any number of counter inputs are easily obtained.

Time-Tagging

Any of the 16 digital inputs may be defined to tag the time of the input event with one millisecond accuracy.

► This time may be read and used in sequence-of-event actions, or used for historical reports.

Optical Isolation

All inputs are protected by optical isolators on the module.

► Surge Withstand Capability (SWC) conformance is assured for the safety of the equipment and technicians.

Packaging

The module is packaged in a plastic housing that plugs and locks into the motherboard. Wire connections (up to 14 ga. wire) are made to removable connectors on the face of the module. No jumpers, calibration pots, etc. are located on the module (any calibration is done electronically via software from the ToolBox program.)

► Modularity allows the MOSCAD RTU to be easily expanded as system requirements change and makes field module replacement quick and easy.

16ac Digital Input Module

SPECIFICATIONS

GENERAL SPECIFICATIONS

Order:	10-28 Vac/dc Inputs: 20-56 Vac/dc Inputs:	Plant installed: V329; Field installed: FLN2006 Plant installed: V379; Field installed: FLN2007
Input Type:	16; may be counters (50 Hz or less); four inputs share a single Common	
Input Signal:	No Input:	<3.5 Vac/dc (10-28 Vac/dc module) <6 Vac/dc (20-56 Vac/dc module)
	Voltage Input:	>8 Vac/dc (10-28 Vac/dc module) >14 Vac/dc (20-56 Vac/dc module)
Input Isolation:	Optical isolation	
Input Protection:	2.5 kV SWC per ANSI C37.90.1-1989	
Diagnostic:	20 LEDs: 16 for inputs, 1 each for Module Fail and No Clock	
Power:	5 Vdc: 20 ma 12 Vdc: 10 ma (50 ma when LEDs are on)	
Environment:	Humidity: 0 to 90% @ +50°C Temperature: -30 to +60°C	

Specifications subject to change without notice.

Typical Output Circuit

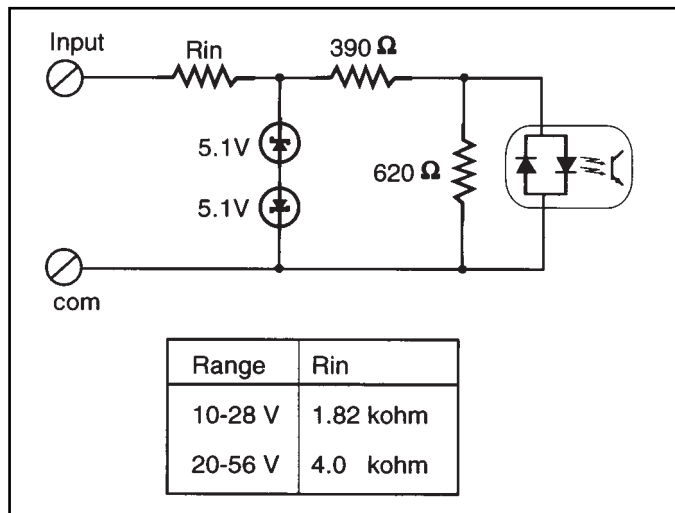

Connections Chart

Term	Function	Term	Function
1	Input1 (+)	11	Input9 (+)
2	Input2 (+)	12	Input10 (+)
3	Input3 (+)	13	Input11 (+)
4	Input4 (+)	14	Input12 (+)
5	common 1-4	15	common 9-12
6	Input5 (+)	16	Input13 (+)
7	Input6 (+)	17	Input14 (+)
8	Input7 (+)	18	Input15 (+)
9	Input8 (+)	19	Input16 (+)
10	common 5-8	20	common 13-16



Midgårdsvägen 20, S-973 34 LULEÅ
 Tel: 0920-22 24 10, Fax: 0920-22 24 20
 E-Mail: info@vianetab.se
 Gsm: 070-545 14 52, 070-545 17 81



SUPPORT SERVICES

Wherever Motorola sells, our product is backed by service. Our products are serviced throughout the world by a wide network of company or authorized independent distributor service organizations.



MOTOROLA

Motorola U.S.A.
 1301 E. Algonquin Road
 Schaumburg, Illinois 60196
 In the U.S. call: 1-800-247-2346

Motorola Canada Limited
 3900 Victoria Park Avenue
 North York, Ontario M2H 3H7
 In Canada call: 1-800-268-5758

Outside the U.S. and Canada call: (847) 538-6602

Ⓜ, and Motorola are trademarks of Motorola. © 1998 by Motorola Inc.

■ Printed in U.S.A. ■ (9803) Merit ■ Produced by Customer Communications.

Motorola is an Equal Employment Opportunity/Affirmative Action Employer